



icotherm
solid roof

Installation Guide

ISSUE 1.7

01.18

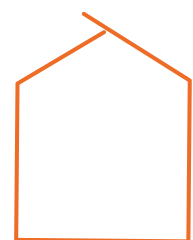

Tools Required To Install Solid Roof

All fixings supplied with roof kit. NB Fixings to house wall not supplied.

IMPORTANT: It is the installer's responsibility to make sure the correct access safety equipment is used during the installation of the Icotherm Solid Roof, such as access ladders and scaffolding.



Hand Saw



Rubber Mallet



13mm Auger Bit



Tape Measure



Pencil



Tin Snips



Clamp



Socket Wrench

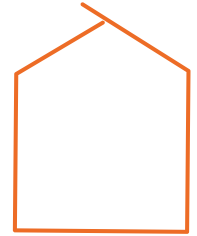

Cordless Drill



Spirit Level



Acro Prop

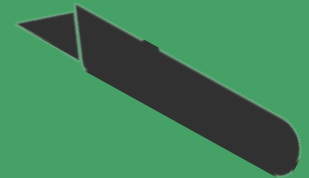

Utility Knife



Angle Grinder



Expanding Foam & Gun



Roofing Stapler



Rip Saw

Setting the Eaves Beam

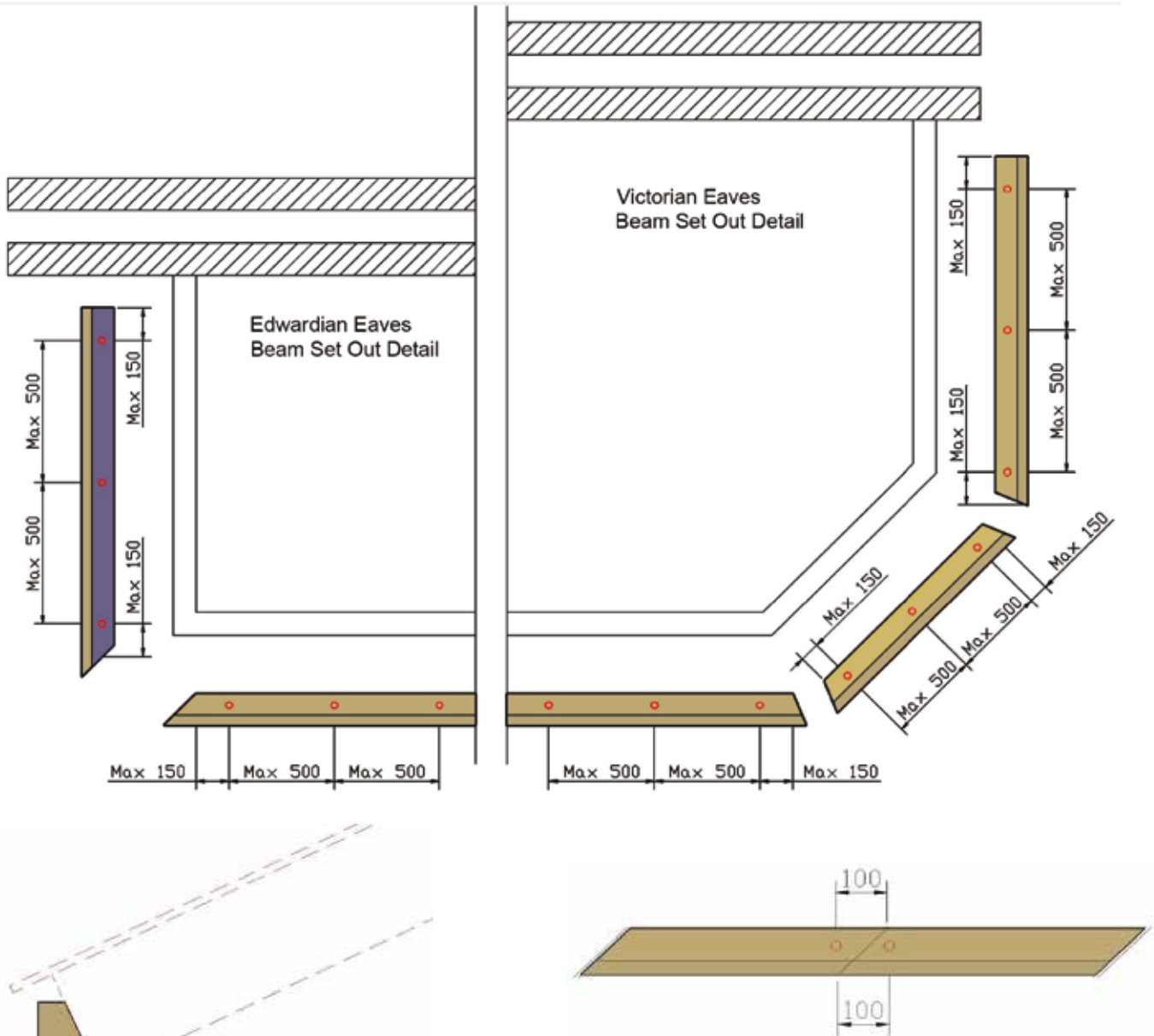

Please Note: When fitting the pods to the eaves make sure the underside of the rafter is level with the underside of the eaves. If the rafter is fitted lower, the roof will not fit.

Fit the eaves to the top of the frames so the inside edge of the eaves is flush with the inside edge of the frame. Use M5 x 90 professional wood screws, fixing through the frame and into the eaves beam at MAX 500mm centres & MAX 150mm in from

the ends of a single eaves. Where eaves beams are longer than 5.3 Mtr, they must be jointed at 45 degrees (pre cut in the factory) and fixed to the frame either side of the joint, 100mm apart.

Eaves Beam Dovetail Fixing

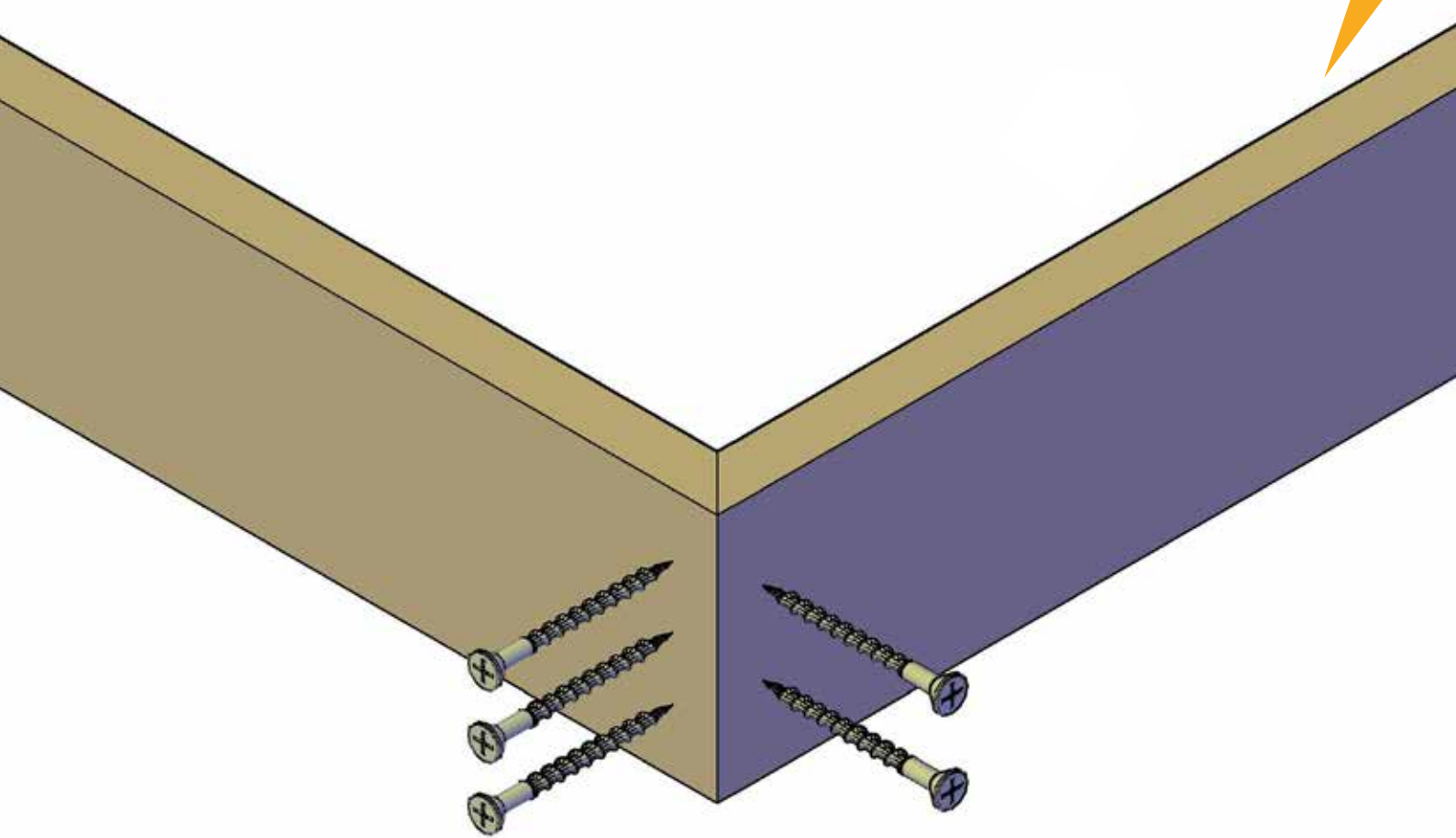

Eaves beam to be dovetail screwed on every corner using M5 x 90mm professional wood screws supplied, 3 through one face and 2 through the opposite face 25mm from the external corner.

Same fixing detail applies for 135°, 110° etc.

Soffit Fixing Detail

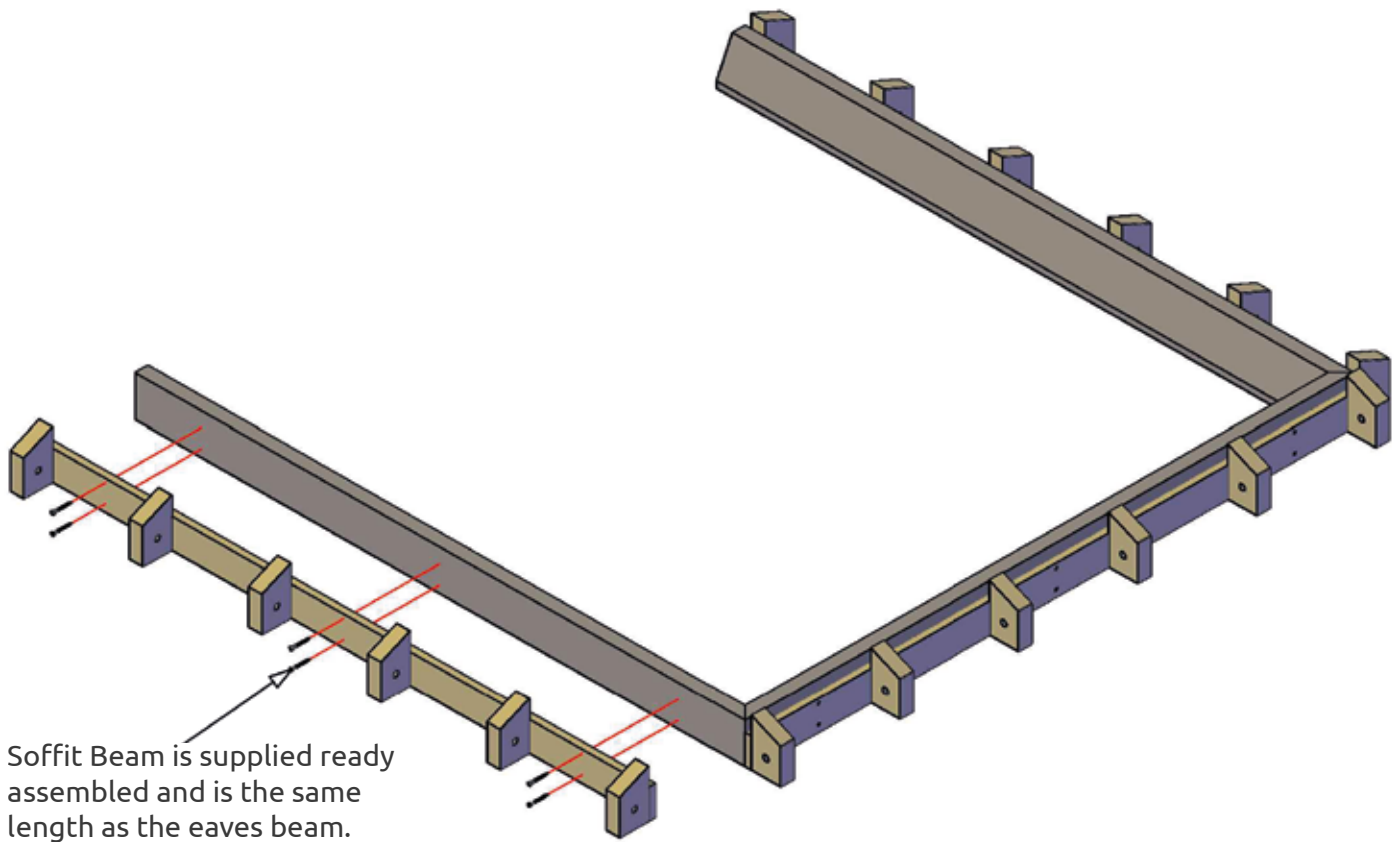

Soffit Beam is supplied ready assembled and is the same length as the eaves beam.

Offer the beam up to the eaves flush with the bottom of the 22mm packer and screw every 800mm with 5 x 70mm screws provided.

Soffit Fixing Detail

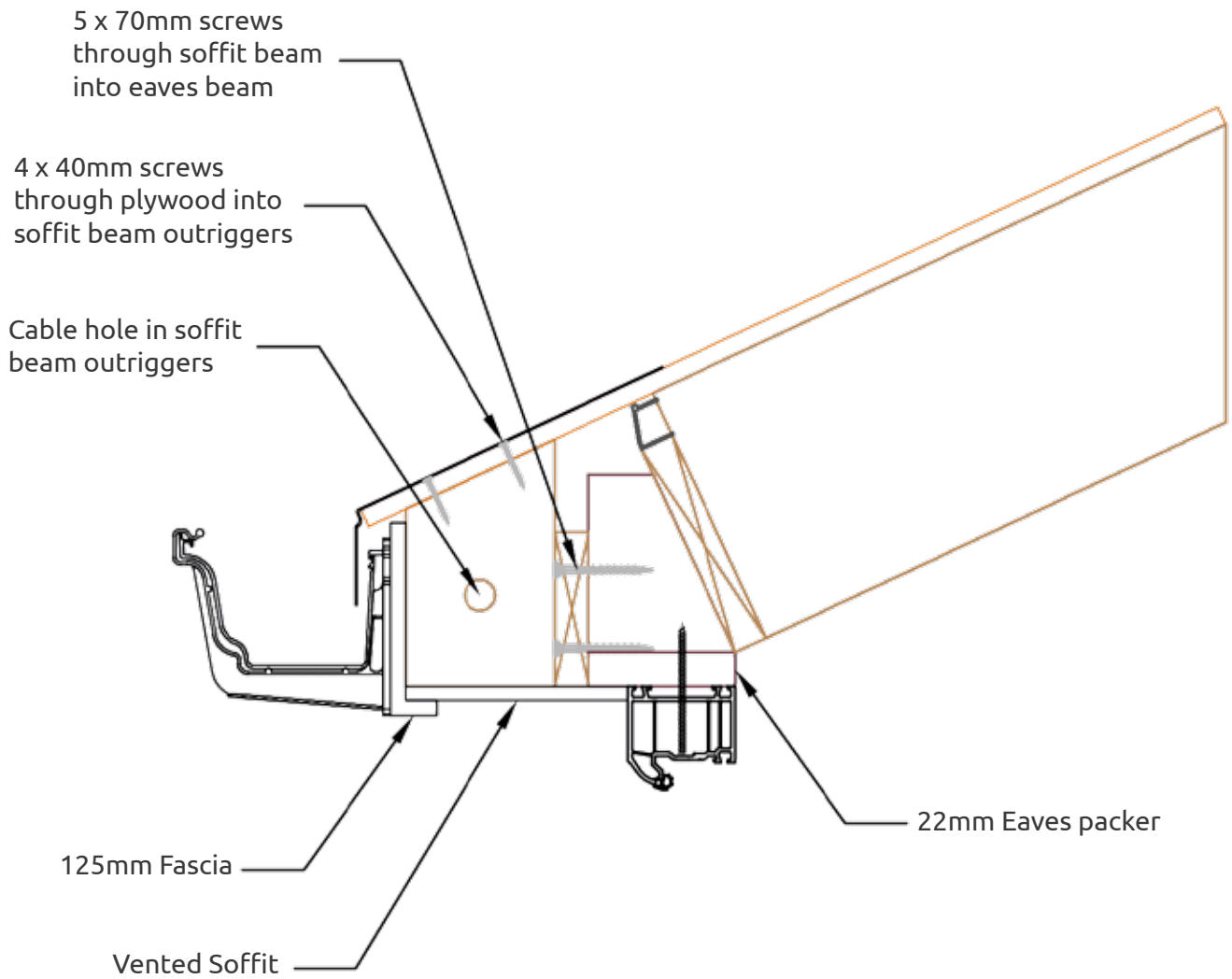
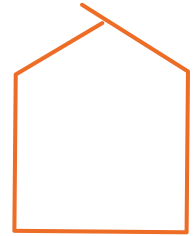

Setting The Ridge

Pre drilled ridge section to be propped at the height given on the drawing provided in box pick bag before offering up the first pod. Offer up the pod and align holes at the ridge and bolt through.
*screw one side to hold in position and bolt when both pods are in place.

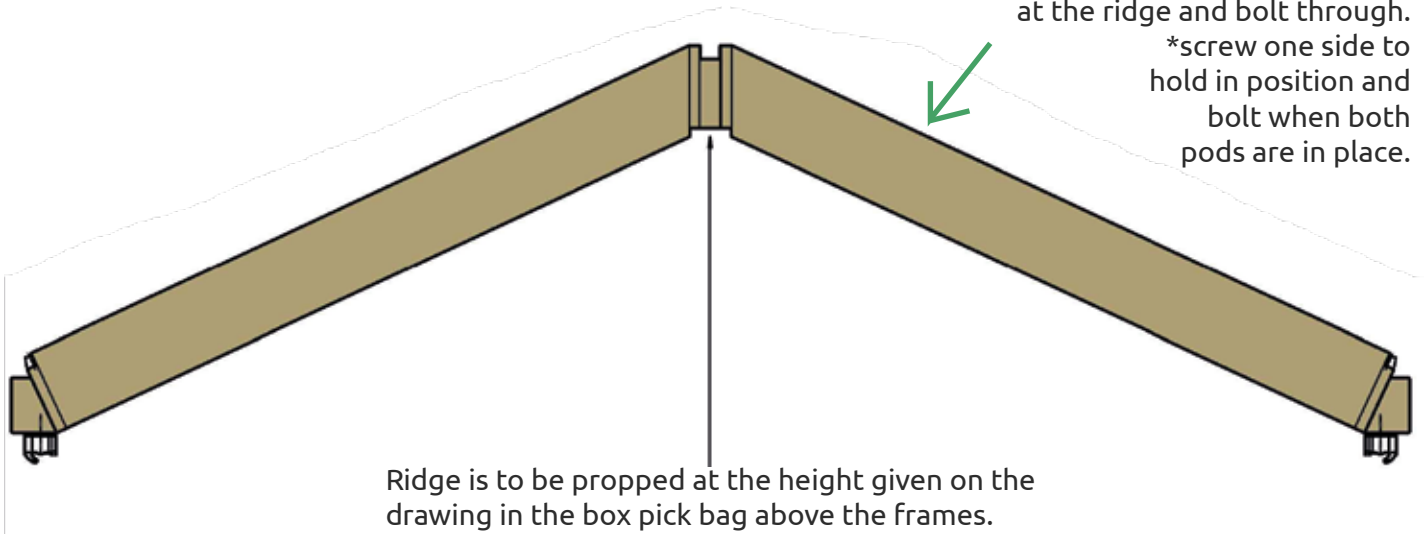

Wall Plate To Wall Fixing Detail

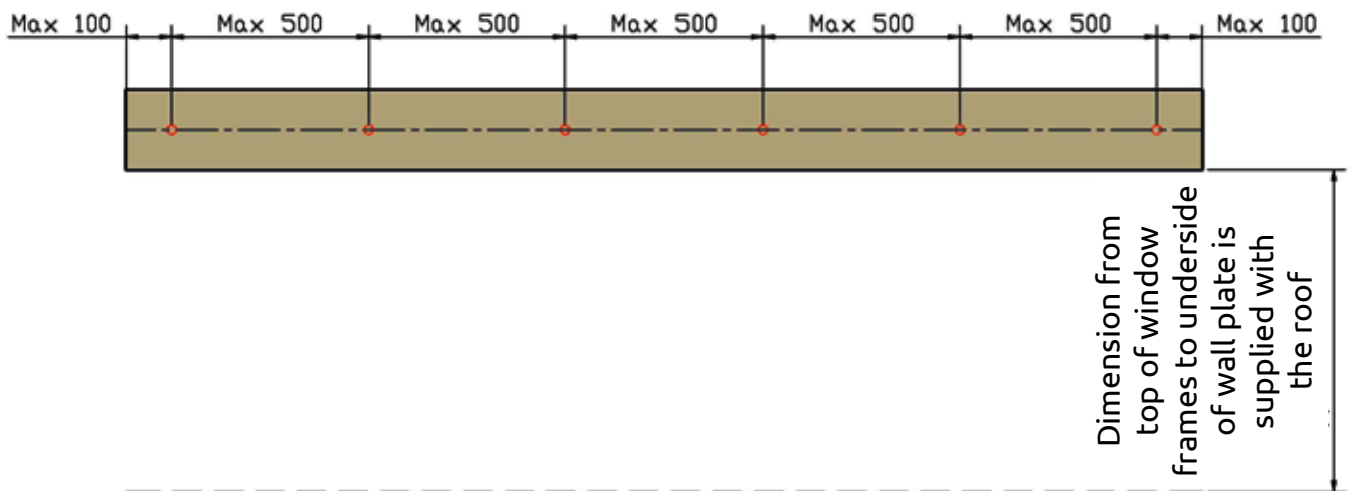

Concrete fixings through the wall plate 100mm in from either side and a max of 500mm centres.

Please Note: Pack wall plate where necessary.

Lean-to Roof Style Pod Assembly Sequence

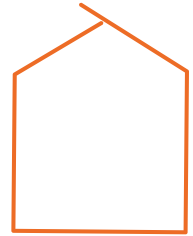

1

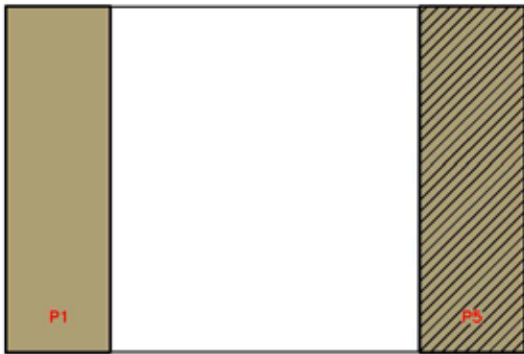

Temporarily fit the end pods to ensure the wall plate is parallel to the eaves. Pack the wall plate where necessary.

2

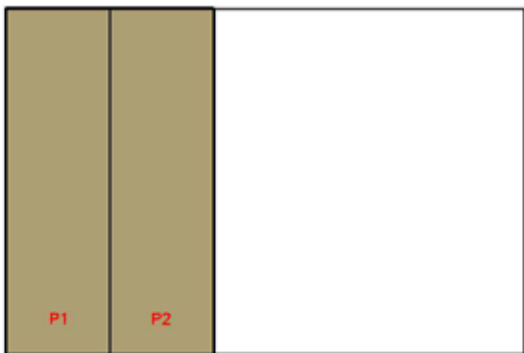

3

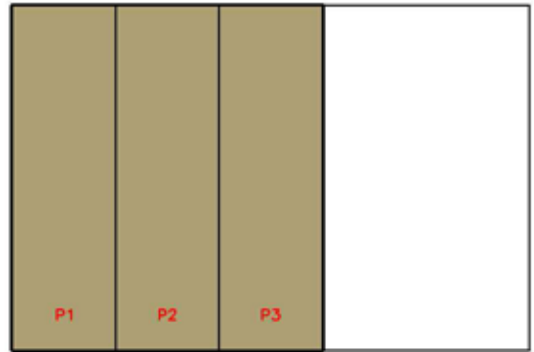

4

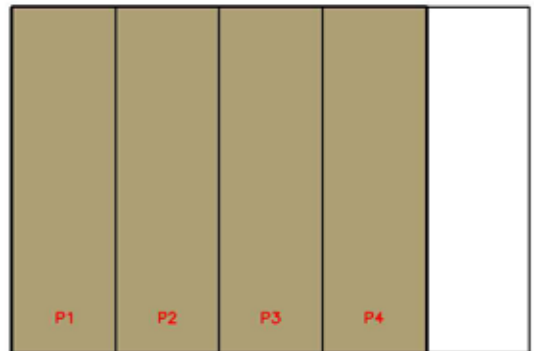

5

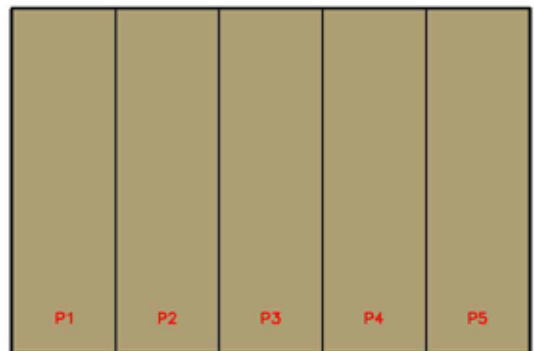

Once the eaves beam and wall plate have been fitted, follow this recommended pod assembly sequence using all the bolts and screws supplied for each pod before moving on to the next pod.

Edwardian Roof Style Pod Assembly Sequence

Once the eaves beam has been fitted follow the recommended pod assembly sequence below using all the bolts and screws supplied for each pod before moving on to the next pod.

1

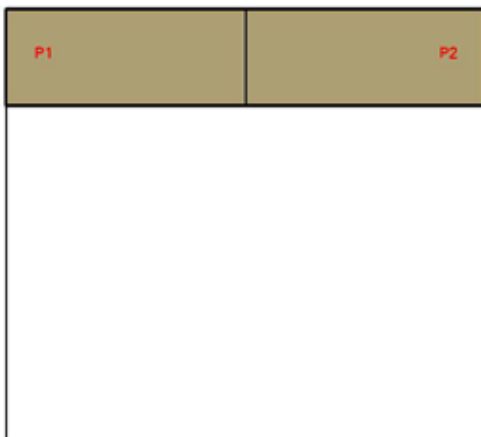

3

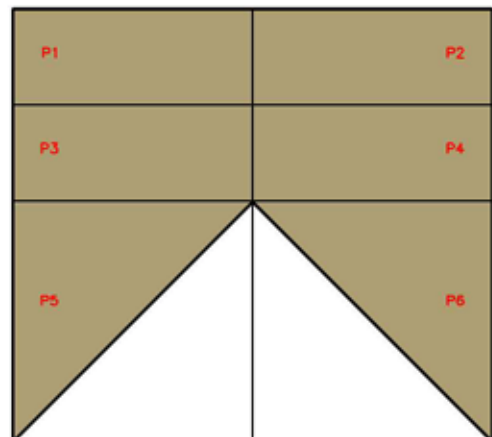

2

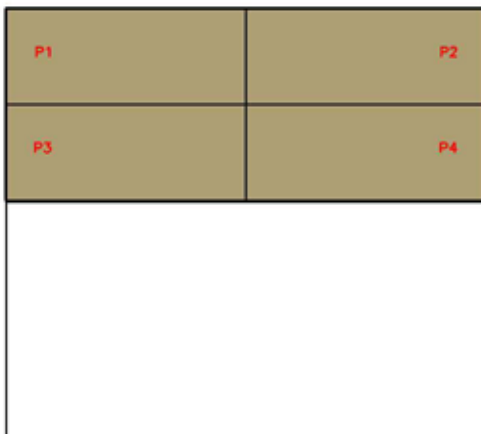

4

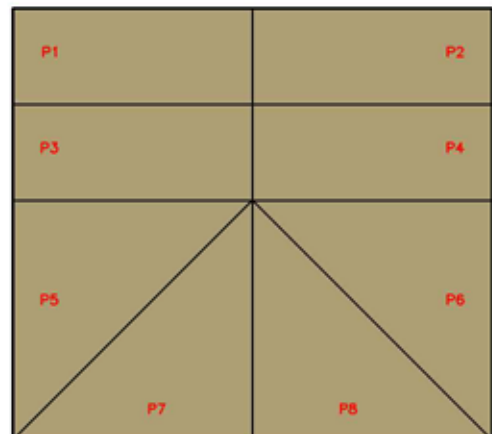

Victorian Roof Style Pod Assembly Sequence

Once the eaves beam has been fitted follow the recommended pod assembly sequence below using all the bolts and screws supplied for each pod before moving on to the next pod.

1

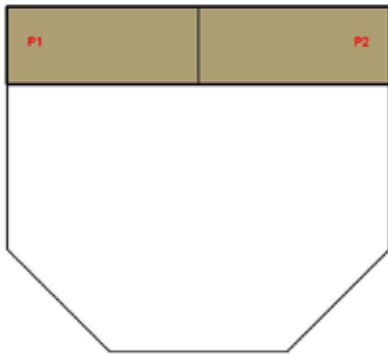

2

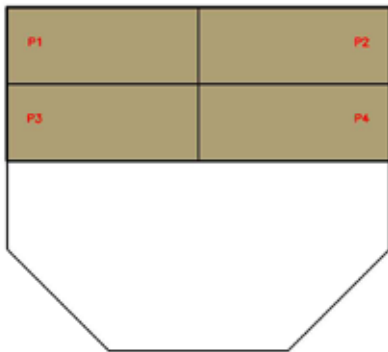

3

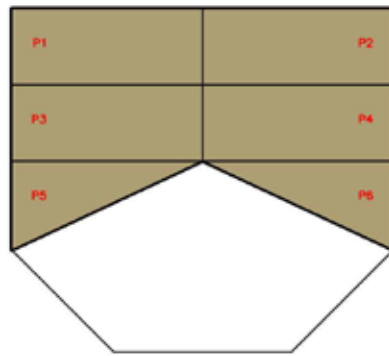

4

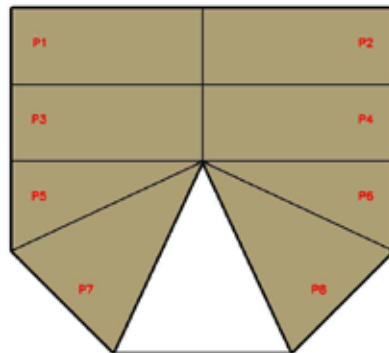

5

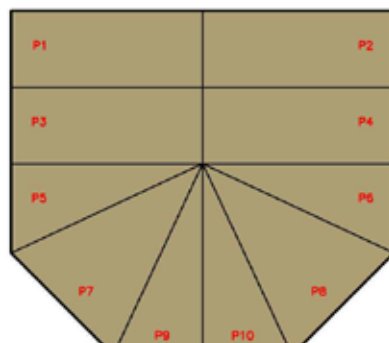

Pod Abutment Fixing Detail

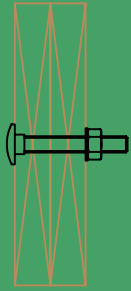

Section A-A

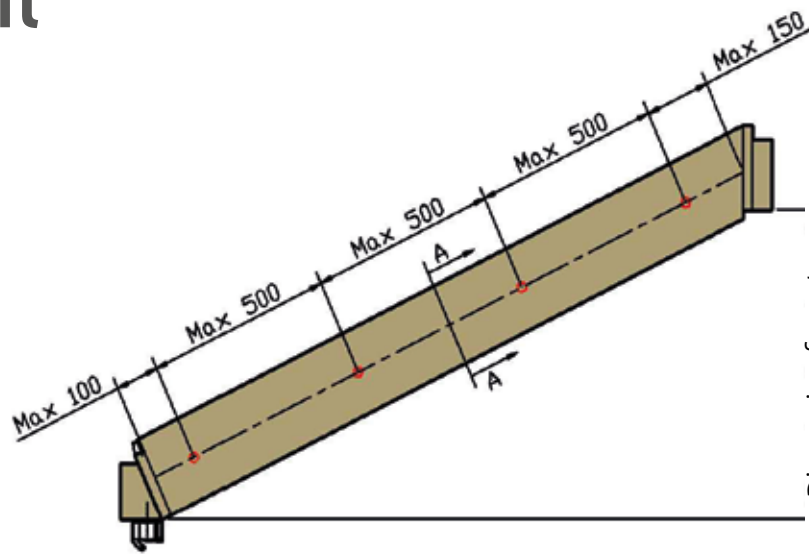

Dimension from top of window frames to underside of the ridge is supplied with the roof.

Slide/Lift the pods over the eaves and lower so that eaves ring beam is flush to the bottom of the eaves and the ridge ring beam is flush with the bottom of the pre-drilled ridge so the bolt holes line up. Fix the pod in place at the ridge with two M12 x 130mm bolts supplied through the pre drilled holes and at the eaves with 5 x 70mm screws supplied making sure there are no gaps between the pods. Drill a 13mm hole through both pod sides 100mm in from the bottom, 150mm from the top and a max of 500mm centres. Fix together with the M12 x 70mm bolts supplied.

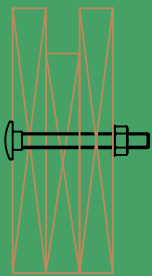

Section B-B

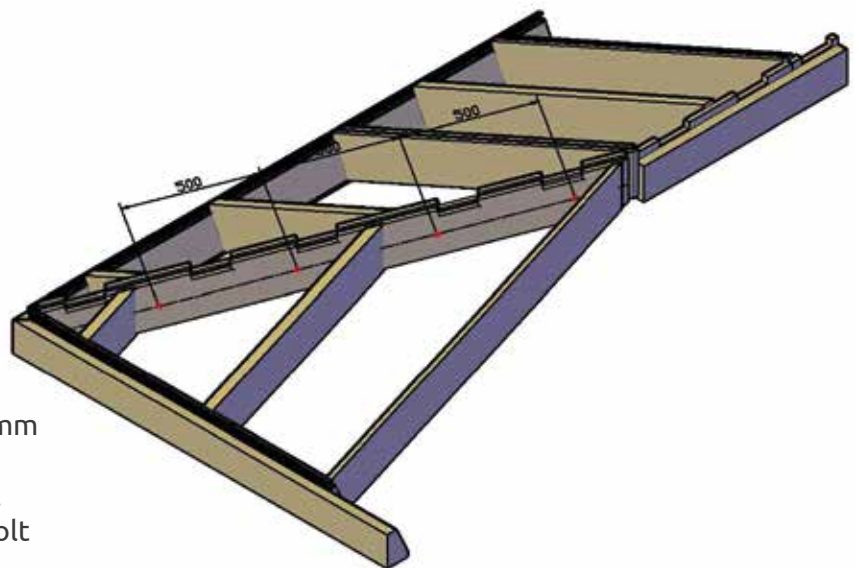

First 13mm hole to be drilled 250mm from the bottom of the hips or as close to 250mm as possible and at 500mm centres where possible, bolt through the hips with the M10 x 90mm bolts supplied. For solid hips see page 19.

Wall Abutment Fixing Detail

Pre drilled ridge section to be propped at the height given on the drawing provided in box pick bag before offering up the first pod. Offer up the pod and align holes at the ridge and bolt through. * Screw one side to hold in position and bolt when both pods are in place.

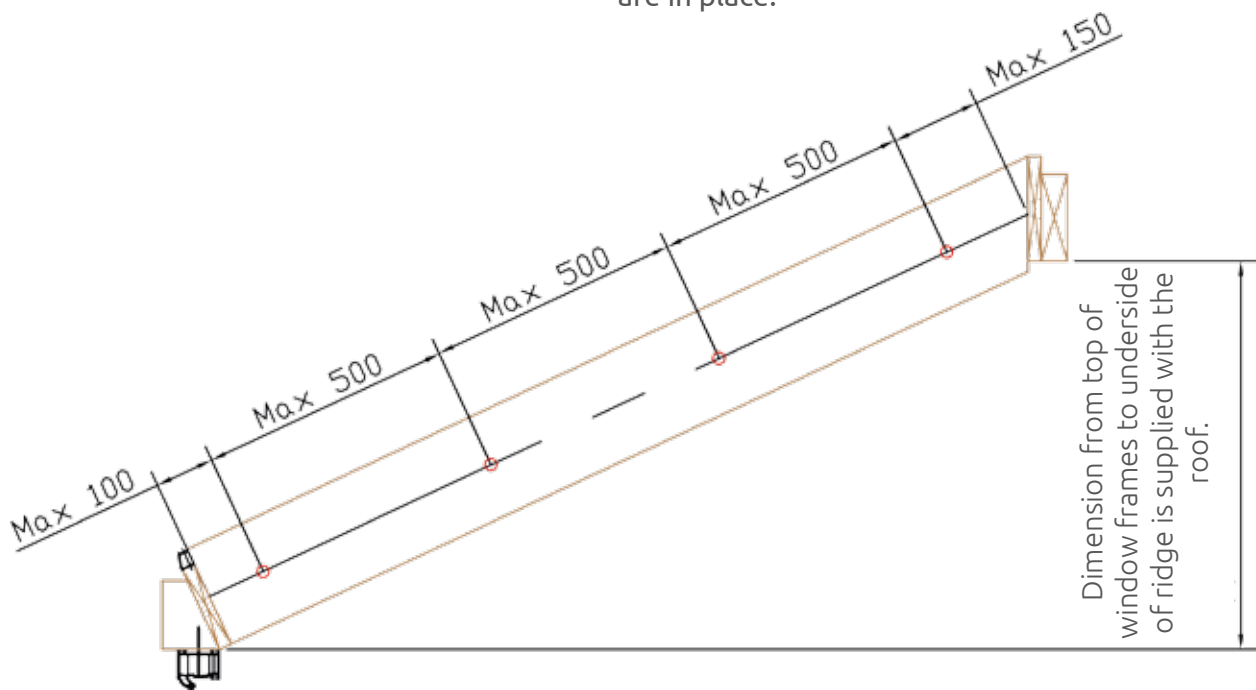

Concrete fixings through the end rafter of the first pod, 100mm up from the bottom, 150mm from the top and a max of 500mm centres.

Important: only fix to the house wall after all the pods are up and fixed together.

Eaves Protector Fixing Detail

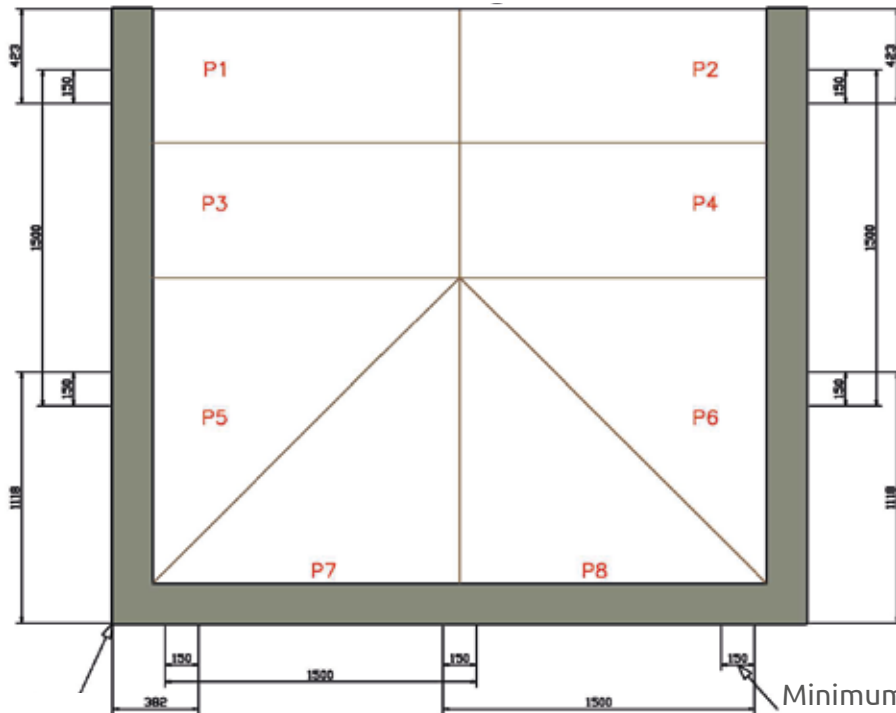

When continuing around a corner cut a diagonal in the top face of the eaves protector and bend around so the face protecting the eaves is continuous, staple in position and trim any over hanging parts.

Minimum of 150mm overlap where eaves protectors are joining.

Plywood Tile Starter is supplied for the steel tiles. It must be fixed over the eaves protector overhanging the plywood roof board by 15mm.

This bend in the eaves protector will flatten when the slates are screwed down.

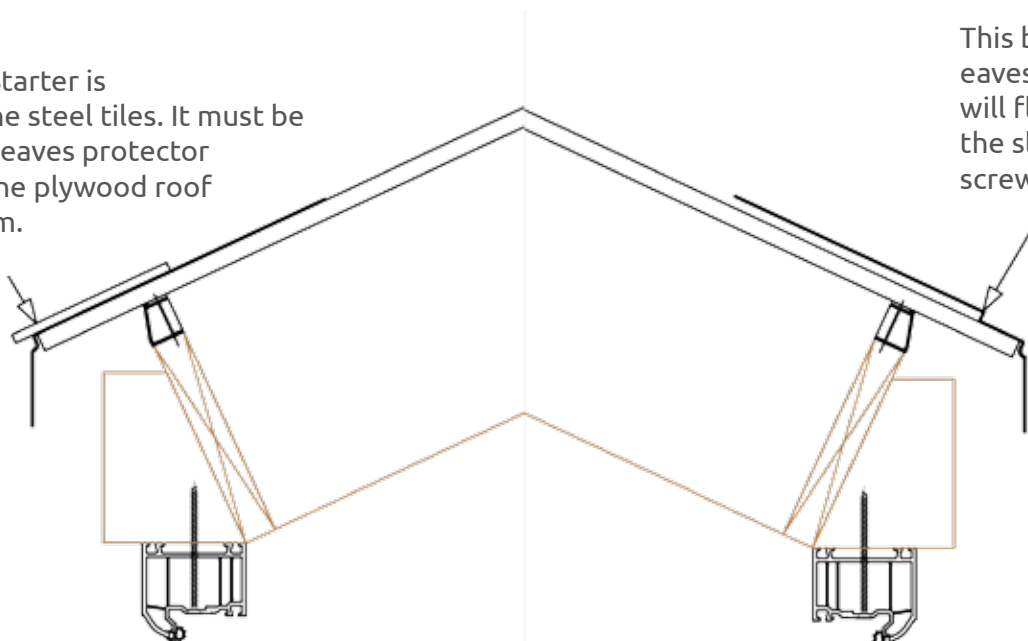

Metrotile Section Showing Eaves Protector Position.

Slate Tile Showing Eaves Protector Position.

Breather Membrane Application

1. Lay the first layer of Breather Membrane leaving no less than 100mm overhang around the edges and no less than 100mm up the abutment wall and staple to the roof.

2. Lay the second layer in the same way, overlapping the first layer and/or ridge no less than 150mm, staple in position.

3. Repeat until roof is covered, making sure that the layer above is always overlapping the layer below to allow any water / moisture to run down and over the membrane and off the roof.

4. If Metrotile / Extralight is being used then the drainage mat must be put over the breather in a similar way but does not need overlapping.

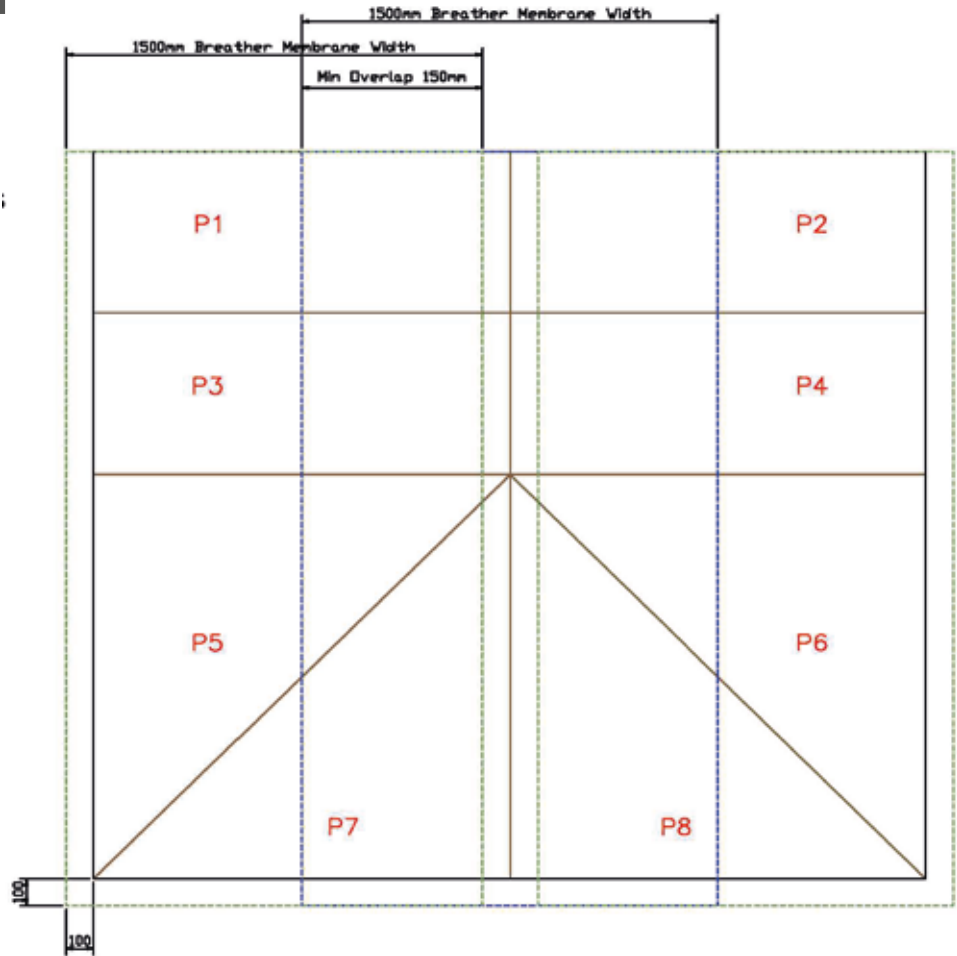

Breather Membrane covers the roof ply and eaves protector. Trim the excess from the 100mm left overhanging earlier back to the eaves protector. The tile starter trim is then fixed down over the breather and drainage mat the first tile then hooks over the starter trim.

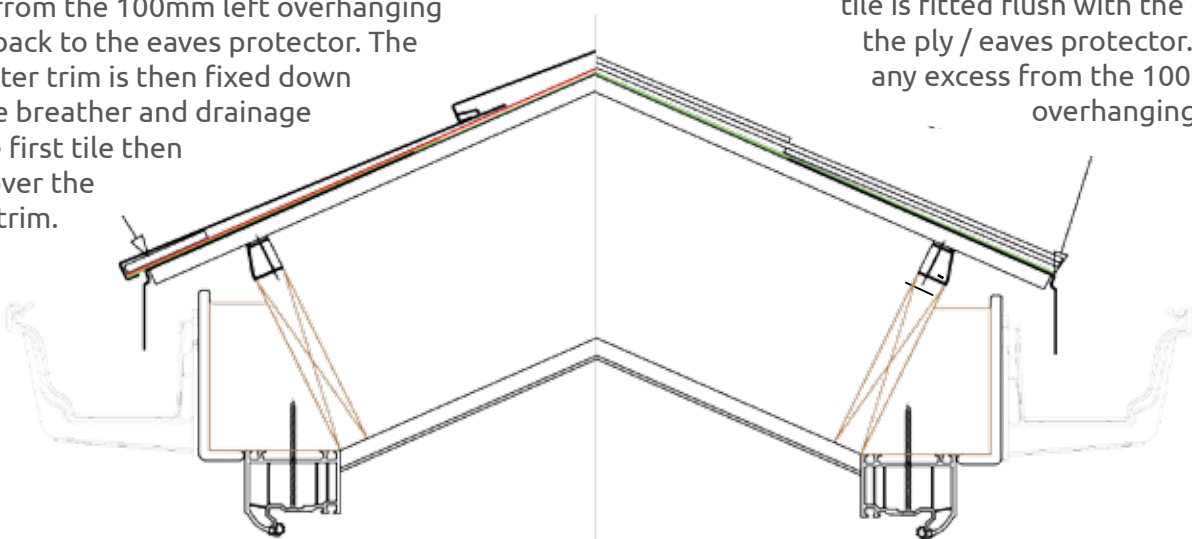

Metrotile/Extralight
Section Showing
Breather Membrane.

Breather Membrane covers the roof ply and eaves protector, the first tile is fitted flush with the edge of the ply / eaves protector. Cut off any excess from the 100mm left overhanging earlier.

Slate Tile
Section Showing
Breather Membrane.

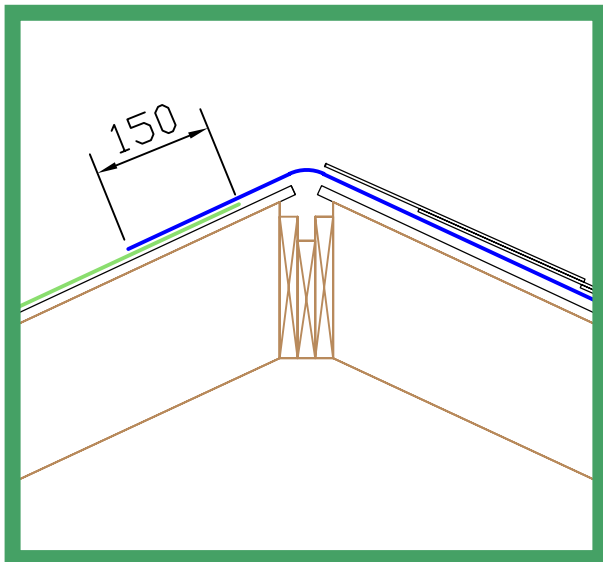

Ridges & Hips

- Lay Breather Membrane over the ridge / hip by no less than 150mm.
- Tile to be cut level with the top of the plywood roof board.

Valleys (with valley tray)

- Lay Breather Membrane running in and out of the valley overlapping by no less than 150mm where necessary.
- Fit the valley tray over the Breather Membrane and overlap the valley trays by no less than 150mm if needed. Valley tray to be fixed in position on the outer most edges.
- Ensure the tile is no less than 100mm over the valley tray.

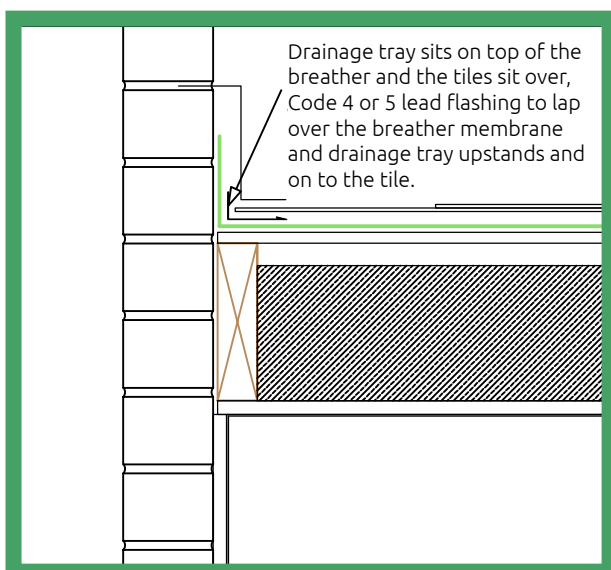
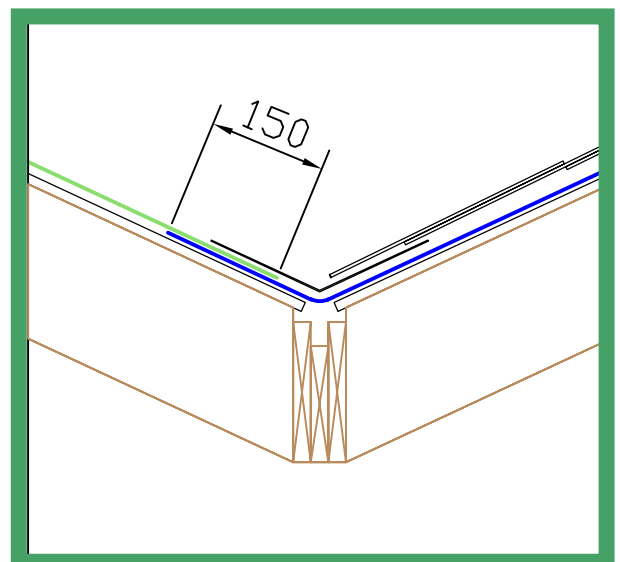

Abutments

- Turn Breather Membrane up against abutment wall by no less than 100mm.
- Fit drainage channel over the Breather Membrane trapping it between the roof board and abutment wall.
- Tile over the drainage channel being careful not to screw through it.
- Fix lead flashing Code 4 or 5, in accordance with current Codes of Practice and manufacturers recommendations.

Steel Boomerang

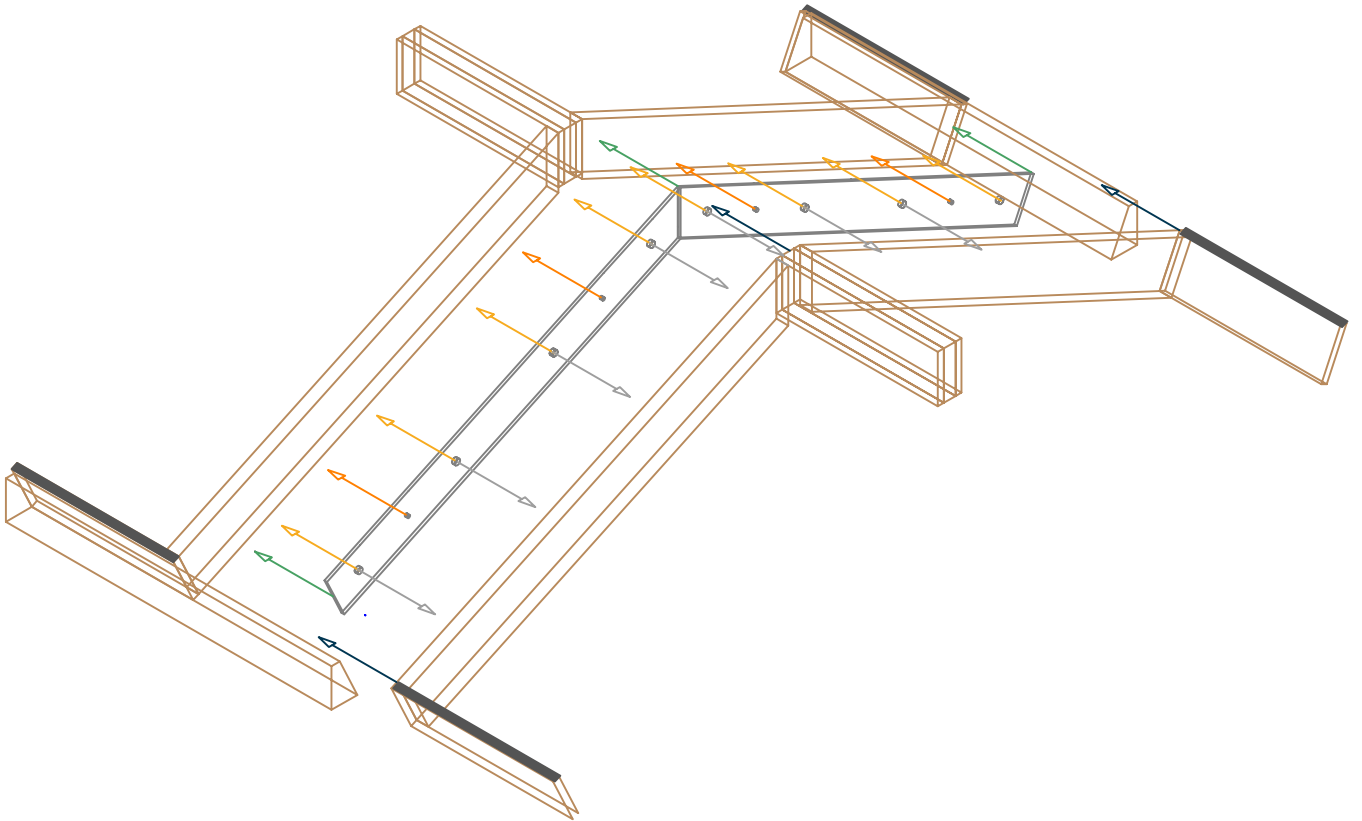

1. Offer up the welded steel boomerang so it is central to the pod rafter.

2. Hold in position and screw in place through the pre drilled 5mm holes.

3. Drill through the 13mm pre drilled holes and through the rafter the steel is screwed too.

4. Fit the next pod so it is tight up to the steel and screw in position at the eaves.

5. Drill through the 13mm holes so you can bolt through the pods, sandwiching the steel between the pods.

Insulation

Void must not be obstructed.

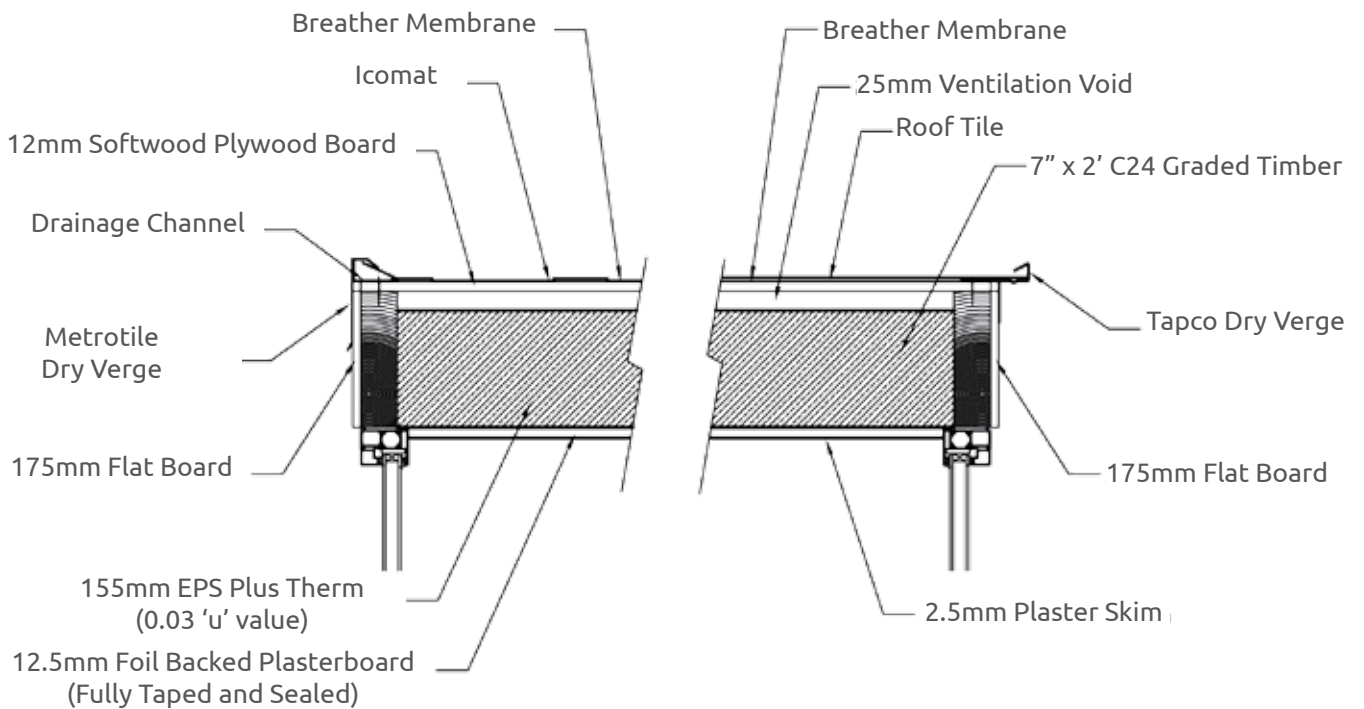

EPS board to be fitted flush with the bottom of the timber rafters.

NB. All EPS board should be tight. Any gaps to be filled with foam, being careful not to overfill and obstruct the ventilation gap, blocking this gap will invalidate your roof warranty.

Box Gutter Detail

Concrete fixing into wall through the top edge of the box gutter before you start to fit any eaves pods.

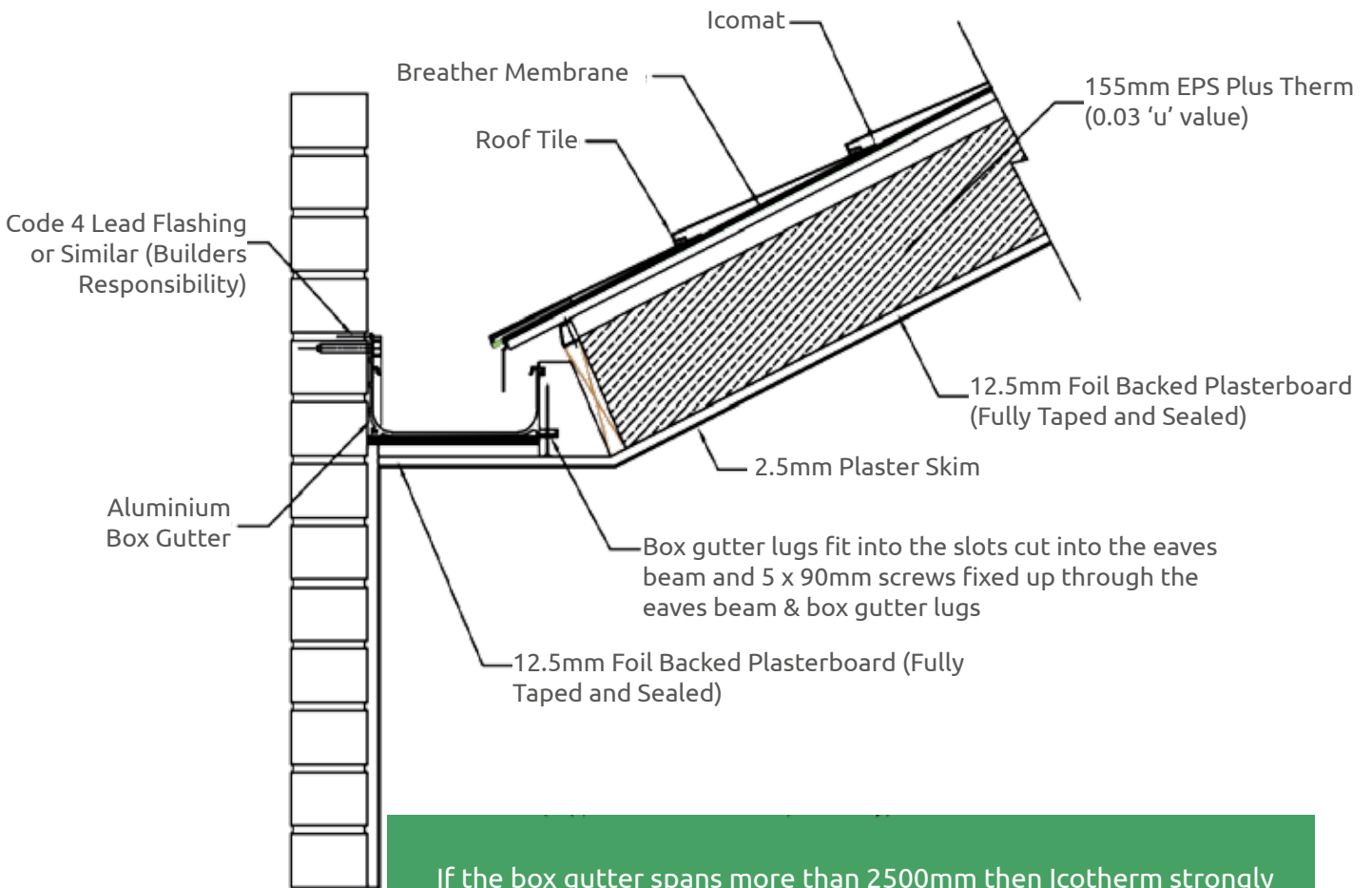
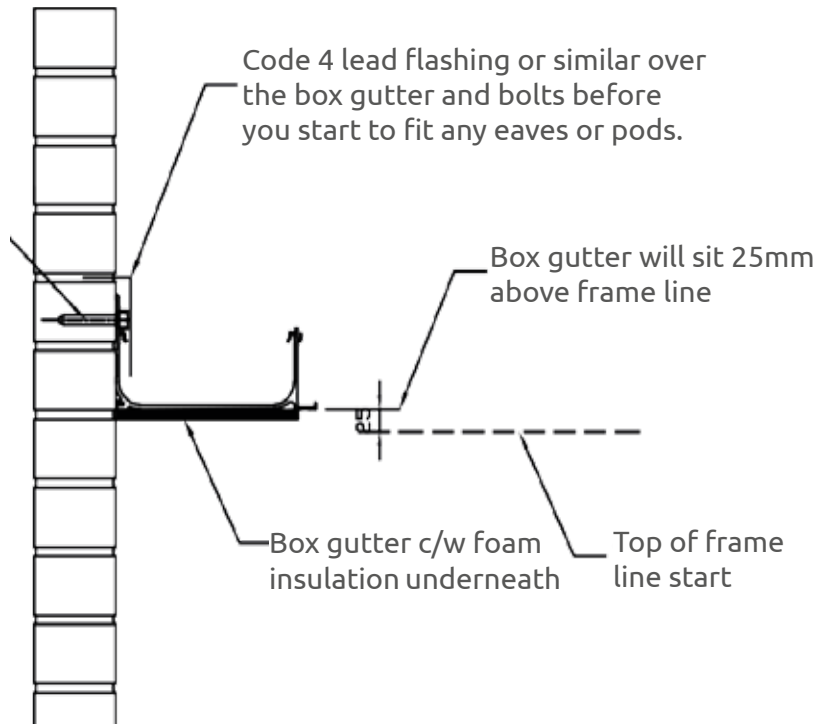

If the box gutter spans more than 2500mm then Icotherm strongly recommends that gallow brackets or similar are used to support the roof (support is the builder's responsibility).

Lean-to Vented Ridge Finishing Detail

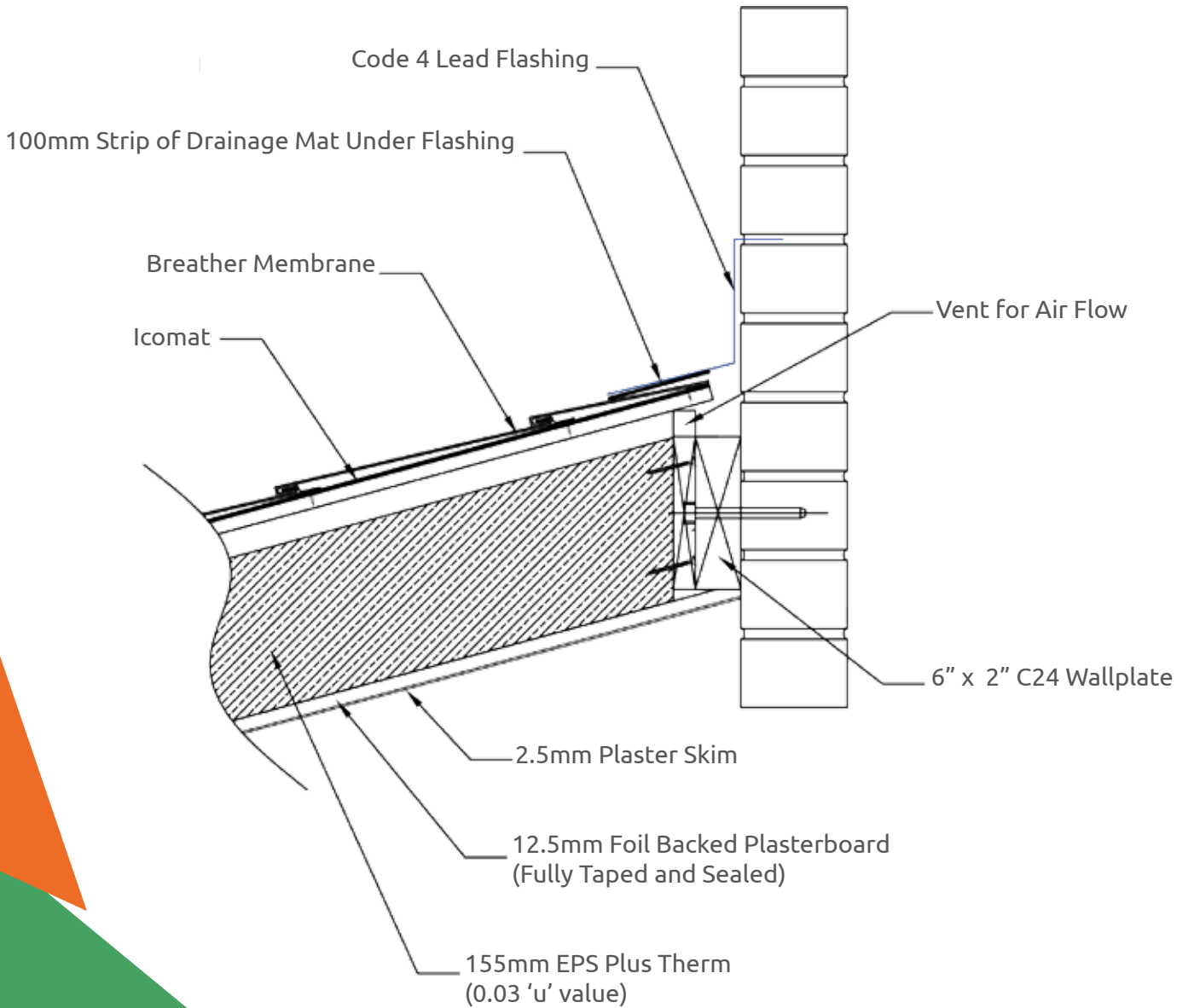

Solid Hips

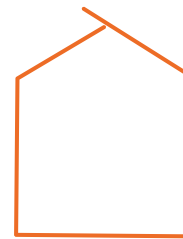

Once the rectangles are up and bolted in position you must fit HP1 on both sides before you fit the solid hip. This will give you the correct position to set the solid hips. Tack both to pod HP1 with 5 x 70mm screws supplied, screw top and bottom as indicated below. Install the remaining pods in this order - HP2, HP3 & HP4. Once all the pods are in place you can bolt through the entire hip assembly with the M10 X 130mm bolts supplied.

Top of the solid hips fit tight up to the ridge point rafter and should be fixed by screwing through the solid hips and into the ridge point rafters and ridge using 5 x 90mm screws supplied.

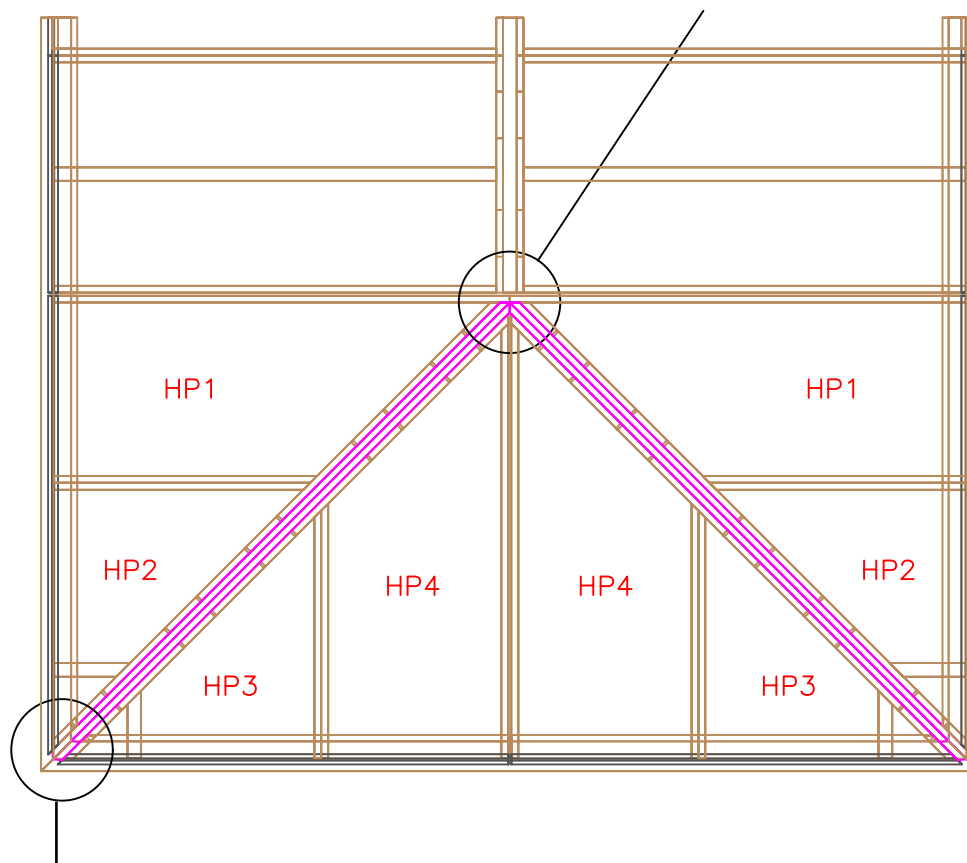

Bottom of the solid hips fit tight up to the internal corner of the eaves, you should fix them by screwing through the front of the eaves and into the solid hips using 5 x 90mm screws supplied.



icotherm
solid roof

01204 773 040

www.icotherm.co.uk

sales@icotherm.co.uk

Unit 3 Osman House, Prince
Street, Bolton, BL1 2NP